

User Manual

M3744 Analog Input Module

4 ch RTD (PT100, PT1000, Ni1000LG), cage clamp, 18 pt removable terminal

Doc ID: 237570
2026-01-08

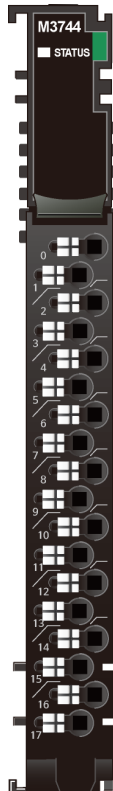

The information in this document is subject to change without notice and is provided as available at the time of printing. Beijer Electronics AB reserves the right to change any information without updating this publication. Beijer Electronics AB assumes no responsibility for any errors that may appear in this document. All examples in this document are only intended to improve understanding of the functionality and handling of the equipment. Beijer Electronics AB cannot assume any liability if these examples are used in real applications. In view of the wide range of applications for this software, users must acquire sufficient knowledge themselves in order to ensure that it is correctly used in their specific application. Persons responsible for the application and the equipment must themselves ensure that each application is in compliance with all relevant requirements, standards, and legislation in respect to configuration and safety. Beijer Electronics AB will accept no liability for any damage incurred during the installation or use of equipment mentioned in this document. Beijer Electronics AB prohibits all modification, changes, or conversion of the equipment.

Head Office

Beijer Electronics AB

Box 426

201 24 Malmö, Sweden

www.beijerelectronics.com / +46 40 358600

Table of Contents

1. About This Manual	5
1.1. Safety Notices in This Manual	5
2. Safety	6
2.1. General Safety Requirements	6
3. Product Certifications	7
4. Main Parts	8
5. Dimensions	9
6. Specifications	10
6.1. Environmental Specifications	10
6.2. General Specifications	10
6.3. Input Specifications	10
7. Wiring Diagram	12
7.1. Required Clearance	13
8. LED Indicator	14
8.1. LED Status	14
9. Mapping Data into the Image Table	15
10. Configuration Parameters (18 Bytes)	16
11. Data Value	18
12. Hardware Setup	19
12.1. Space Requirements	19
12.2. Mount to DIN-rail	20
12.3. Power Wiring	21
13. Hot Swap (Module Replacement During Operation)	23
13.1. Hot Swap Safety Information	23
13.2. Hot Swap Instructions	23

1. About This Manual

This manual describes the software and hardware features of the Beijer Electronics M3744 Analog Input Module. It provides detailed specifications and instructions for installation, setup, and operation.

1.1. Safety Notices in This Manual

This manual uses safety notices to highlight important information. Always read and follow these notices.



WARNING

If you do not follow this notice, it can cause death, serious injury, or major damage to the product.



CAUTION

If you do not follow this notice, it can damage equipment, cause data loss, or result in minor injury.



IMPORTANT

Information you must know to use the product correctly.



NOTE

Useful facts or conditions.



TIP

Helpful information that is not essential.

2. Safety

Read this manual and all related manuals carefully before using the product. Always follow the safety instructions.

Beijer Electronics is not responsible for any damages caused by the use of this product.

The images, examples, and diagrams in this manual are for illustration only. Because each installation is different, Beijer Electronics cannot take responsibility for actual results based on these examples.

2.1. General Safety Requirements



WARNING

- **Never assemble or wire products with power applied to the system.** This can cause arc flash, burns, fire, flying objects, blast pressure, or heat.
- **Do not touch terminal blocks or IO modules while the system is running.** This may cause electric shock, short circuit, or malfunction.
- **Do not allow external metallic objects to touch the product** during operation. This may cause electric shock, short circuit, or malfunction.
- **Do not place the product near flammable materials.** This may cause fire.



CAUTION

- Use the product only in **non-hazardous locations** or in **Class I, Zone 2, Groups A, B, C, and D hazardous locations**.
- Only connect **approved products** to the connectors. Do not connect other devices such as converters.
- Ground the workplace, packing, and personnel when handling the modules. Avoid touching conductive parts. The electronic components may be damaged by **electrostatic discharge (ESD)**.
- Do not expose the product to excessive vibration, see [Environmental Specifications](#) for vibration resistance.
- Follow the specifications for input and output connections.
- Do not use the product in environments **above 60 °C** or in direct sunlight.
- Do not use the product in environments with **humidity above 90%**.
- Use the product only in environments with **Pollution Degree 2 or lower** (defined in **EN 60664-1**).
- Make sure transient disturbances do not exceed **140% of the rated voltage**.
- Install the product in an enclosure with a protection rating of **at least IP54**, according to **EN 60079-7**.
- When used in hazardous locations, make sure the **enclosure is certified** for the intended area classification.
- Install the product in an enclosure with a door or cover that requires a tool to open.

3. Product Certifications

For product certifications, visit the **Resources** section on the [M-series product pages](#).

4. Main Parts

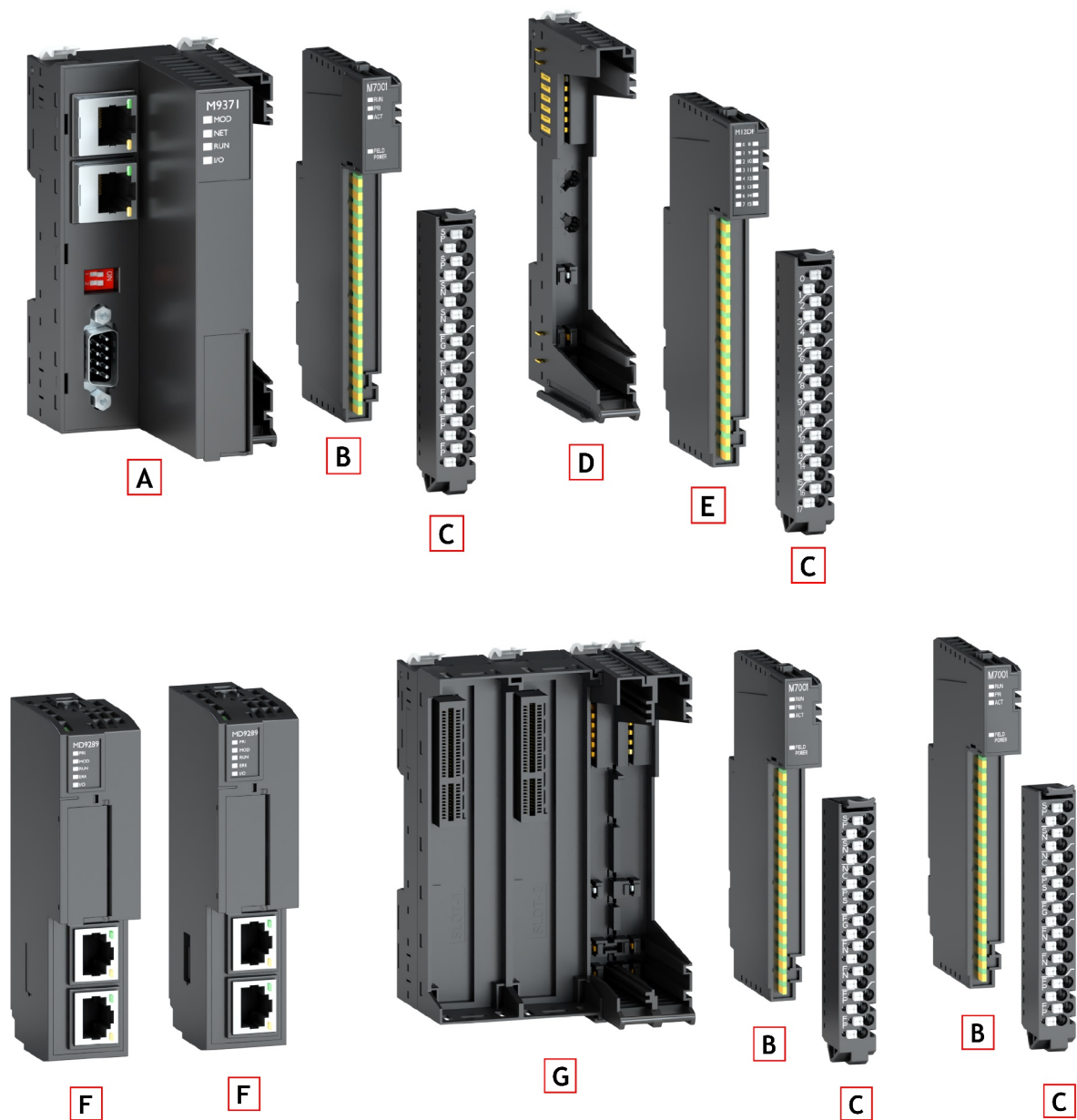

- A. Single network adapter module with backplane for Power module
- B. Main block (Power module)
- C. Removable terminal block
- D. Backplane for Input/Output, Special and Power modules
- E. Main block (Digital input module)
- F. Main block (Dual network adapter module)
- G. Backplane for Dual network adapter modules and Power modules

5. Dimensions



Module dimensions (mm)



6. Specifications

6.1. Environmental Specifications

Operating temperature	-20 °C - 60 °C
UL temperature	-20 °C - 60 °C
Storage temperature	-40 °C - 85 °C
Relative humidity	5% - 90% non-condensing
Mounting	DIN rail
Shock operating	IEC 60068-2-27 (15 g)
Vibration resistance	IEC 60068-2-6 (4 g)
Industrial emissions	EN 61000-6-4: 2019
Industrial immunity	EN 61000-6-2: 2019
Installation position	Vertical and horizontal
Product certifications	Visit the Resources section on the M-series product pages .

6.2. General Specifications

Power dissipation	Max. 120 mA at 5 VDC
Isolation	I/O to Logic: Isolation Field power: Not connected
Field power	Passes through to the next module (AC power not used)
Single wire	0.205 mm ² - 1.3 mm ² (24-16 AWG)
Torque	0.8 Nm (7 lb-in)
Weight	72 g
Module dimensions	See Dimensions .
Hot swap	Supported, see Hot Swap (Module Replacement During Operation) .

6.3. Input Specifications

Number of inputs	4 channels
Indicators (logic side)	4 green input status LEDs
Sensor types - RTD input range	<ul style="list-style-type: none"> • PT50, PT100, PT200, PT500, PT1000: -200 - 850 °C • JPT50, JPT100, JPT200, JPT500, JPT1000: -200 - 640 °C • Ni100, Ni200, Ni500, Ni1000: -60 - 250 °C • Ni120: -80 - 260 °C • Cu10, Cu100: -100 - 260 °C • Ni1000LG: -50 - 120 °C

Sensor types - Resistance input range	<ul style="list-style-type: none"> • 1 Ω/bit: 0 - 4000 Ω • 100 mΩ/bit: 0 - 2000 Ω • 10 mΩ/bit: 0 - 327 Ω • 20 mΩ/bit: 0 - 620 Ω • 50 mΩ/bit: 0 - 1200 Ω
Excitation current	Approx. 0.5 mA
Connection method	4-wire
Conversion time	< 60 ms (all channels)
Data format	16-bit signed integer (two's complement)
Module accuracy	<ul style="list-style-type: none"> • PT50, JPT50, Ni100, Ni120: <ul style="list-style-type: none"> • $\pm 0.3\%$ full scale at 25 °C • $\pm 0.5\%$ full scale at -40-70 °C • PT1000: <ul style="list-style-type: none"> • ± 0.3 °C at 50-150 °C (25 °C ambient) • ± 0.5 °C at 50-150 °C (-25-60 °C ambient) • ± 0.5 °C at -200-250 °C (25 °C ambient) • Cu10: <ul style="list-style-type: none"> • $\pm 2\%$ full scale (25 °C ambient) • $\pm 4\%$ full scale (-25-60 °C ambient) • Cu100: <ul style="list-style-type: none"> • $\pm 0.3\%$ full scale (25 °C ambient) • $\pm 0.5\%$ full scale (-25-60 °C ambient) • All input types: <ul style="list-style-type: none"> • $\pm 0.1\%$ full scale (25 °C ambient) • $\pm 0.3\%$ full scale (-25-60 °C ambient)
Resolution of data	<ul style="list-style-type: none"> • RTD type: ± 0.1 °C / °F • Resistance type: 1 Ω, 100 mΩ, 10 mΩ, 20 mΩ, 50 mΩ
Calibration	Not required
Diagnostics	Sensor open or out of range: conversion data = 0x8000 (-32768)

7. Wiring Diagram

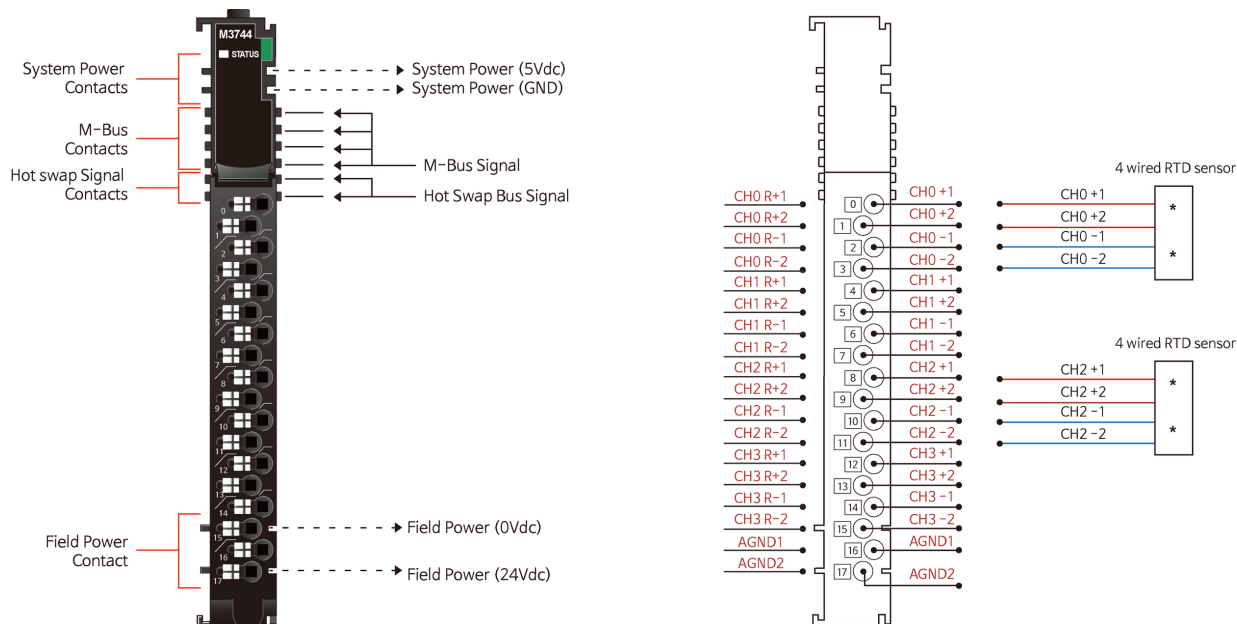

Pin no.	Description
0	RTD channel 0 R+1
1	RTD channel 0 R+2
2	RTD channel 0 R-1
3	RTD channel 0 R-2
4	RTD channel 1 R+1
5	RTD channel 1 R+2
6	RTD channel 1 R-1
7	RTD channel 1 R-2
8	RTD channel 2 R+1
9	RTD channel 2 R+2
10	RTD channel 2 R-1
11	RTD channel 2 R-2
12	RTD channel 3 R+1
13	RTD channel 3 R+2
14	RTD channel 3 R-1
15	RTD channel 3 R-2
16	Analog ground 1
17	Analog ground 2

7.1. Required Clearance

Maintain the following minimum spacing between:

- Uninsulated live parts of opposite polarity.
- Uninsulated live parts and any grounded part, including mounting surfaces or exposed metal parts.

RTB type	Through air	Over surface	CTI*
RTB18C	1.5 mm	1.5 mm	$175 \leq \text{CTI} \leq 400$

* Defines the relationship between the Comparative Tracking Index of an insulating material and the required clearance (or creepage) between conductors in electrical applications or on a printed circuit board (PCB).

8. LED Indicator



LED	Description	Color
STATUS	M-bus status	Green

8.1. LED Status

Status	LED state	Description
M-bus status	Off	No connection
	Green	Connected

9. Mapping Data into the Image Table

Input module data

Analog input Ch 0
Analog input Ch 1
Analog input Ch 2
Analog input Ch 3



Input image value

Bit no.	Bit7	Bit6	Bit5	Bit4	Bit3	Bit2	Bit1	Bit0
Byte 0	Analog input Ch 0 low byte							
Byte 1	Analog input Ch 0 high byte							
Byte 2	Analog input Ch 1 low byte							
Byte 3	Analog input Ch 1 high byte							
Byte 4	Analog input Ch 2 low byte							
Byte 5	Analog input Ch 2 high byte							
Byte 6	Analog input Ch 3 low byte							
Byte 7	Analog input Ch 3 high byte							



NOTE

If a channel input is open or out of range, its conversion data will be 0x8000 (–32768).

10. Configuration Parameters (18 Bytes)

Byte	Bit / Range	Description	Default
0	00-07	Sensor type selection: <ul style="list-style-type: none"> • 00h: PT100, 0.00385, -200-850 °C, 0.1 °C/count • 01h: PT200, 0.00385, -200-850 °C, 0.1 °C/count • 02h: PT500, 0.00385, -200-850 °C, 0.1 °C/count • 03h: PT1000, 0.00385, -200-850 °C, 0.1 °C/count • 04h: PT50, 0.00385, -200-850 °C, 0.1 °C/count • 10h: JPT100, 0.003916, -200-640 °C, 0.1 °C/count • 11h: JPT200, 0.003916, -200-640 °C, 0.1 °C/count • 12h: JPT500, 0.003916, -200-640 °C, 0.1 °C/count • 13h: JPT1000, 0.003916, -200-640 °C, 0.1 °C/count • 14h: JPT50, 0.003916, -200-640 °C, 0.1 °C/count • 20h: Ni100, 0.00618, -60-250 °C, 0.1 °C/count • 21h: Ni200, 0.00618, -60-250 °C, 0.1 °C/count • 22h: Ni500, 0.00618, -60-250 °C, 0.1 °C/count • 23h: Ni1000, 0.00618, -60-250 °C, 0.1 °C/count • 30h: Ni120, 0.00672, -80-250 °C, 0.1 °C/count • 40h: Cu10, 0.00427, -100-260 °C, 0.1 °C/count • 41h: Cu100, 0.00427, -100-260 °C, 0.1 °C/count • 53h: Ni1000LG, 0.00500, -50-120 °C, 0.1 °C/count • 80h: Resistance, 1-2000 Ω, 100 mΩ/count • 81h: Resistance, 1-327 Ω, 10 mΩ/count • 82h: Resistance, 1-620 Ω, 20 mΩ/count • 83h: Resistance, 1-1200 Ω, 50 mΩ/count • 84h: Resistance, 1-4000 Ω, 1 Ω/count • Others: Reserved 	0 (PT100)
1	00	Temperature type: <ul style="list-style-type: none"> • 0: Celsius (°C) • 1: Fahrenheit (°F) 	0 (°C)
	01	Reserved	
	02	Data resolution: <ul style="list-style-type: none"> • 00: 0.1 °C/°F per bit • 01: 1 °C/°F per bit • 10: 0.01 °C/°F per bit* • 11: Reserved 	0 (0.1 °C)
<p>* Data exceeding 32767 cannot be displayed.</p> <p>** If you set a Fast Filter, the specification accuracy may not be met.</p>			

Byte	Bit / Range	Description	Default
	03	Reserved	
	04	Filter type: <ul style="list-style-type: none"> • 0: Normal filter • 1: Enhanced filter 	0 (Normal)
	05-06	SW filter: <ul style="list-style-type: none"> • 0: Normal (filter time = 20) • 1: Fast (filter time = 3) ** • 2: Enhanced (filter time = 40) • 3: More Enhanced (filter time = 80) 	0 (Normal)
	07	Reserved	
2-3	—	Channel 0 offset value	0
4-5	—	Channel 1 offset value	0
6-7	—	Channel 2 offset value	0
8-9	—	Channel 3 offset value	0
* Data exceeding 32767 cannot be displayed.			
** If you set a Fast Filter, the specification accuracy may not be met.			

11. Data Value

RTD input range

Type	Input range
PT100	-200-850 °C
PT200	-200-850 °C
PT500	-200-850 °C
PT1000	-200-850 °C
PT50	-200-850 °C
JPT100	-200-640 °C
JPT200	-200-640 °C
JPT500	-200-640 °C
JPT1000	-200-640 °C
JPT50	-200-640 °C
Ni100	-60-250 °C
Ni200	-60-250 °C
Ni500	-60-250 °C
Ni1000	-60-250 °C
Ni120	-80-260 °C
Cu10	-100-260 °C
Cu100	-100-260 °C
Ni1000LG	-50-120 °C

Resistance input range

Type	Input range
1 Ω/bit	0-4000 Ω
100 mΩ/bit	0-2000 Ω
10 mΩ/bit	0-327 Ω
20 mΩ/bit	0-620 Ω
50 mΩ/bit	0-1200 Ω

12. Hardware Setup

This section describes how to install the M-series modules.



WARNING

Always read the [General Safety Requirements](#) before installation.

12.1. Space Requirements

The following drawings show the space requirements when installing the M-series modules. The spacing creates space for ventilation, and prevents conducted electromagnetic interference from influencing the operation. Installation position is valid vertical and horizontal. The drawings are illustrative and may be out of proportion.



CAUTION

Not following the space requirements may result in damaging the product.

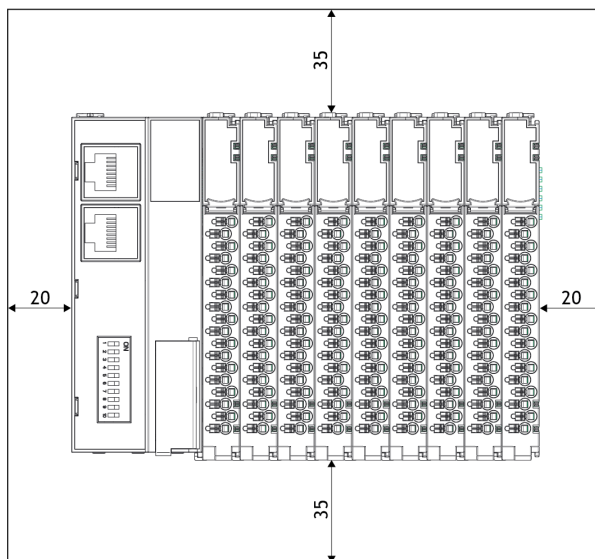

Vertical and horizontal space requirements (mm)

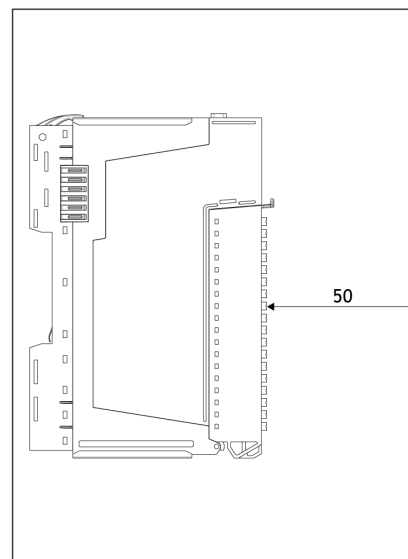

Required distance to door (mm)

12.2. Mount to DIN-rail

This chapter describes how to mount and unmount the module on the DIN rail.

Mounting steps

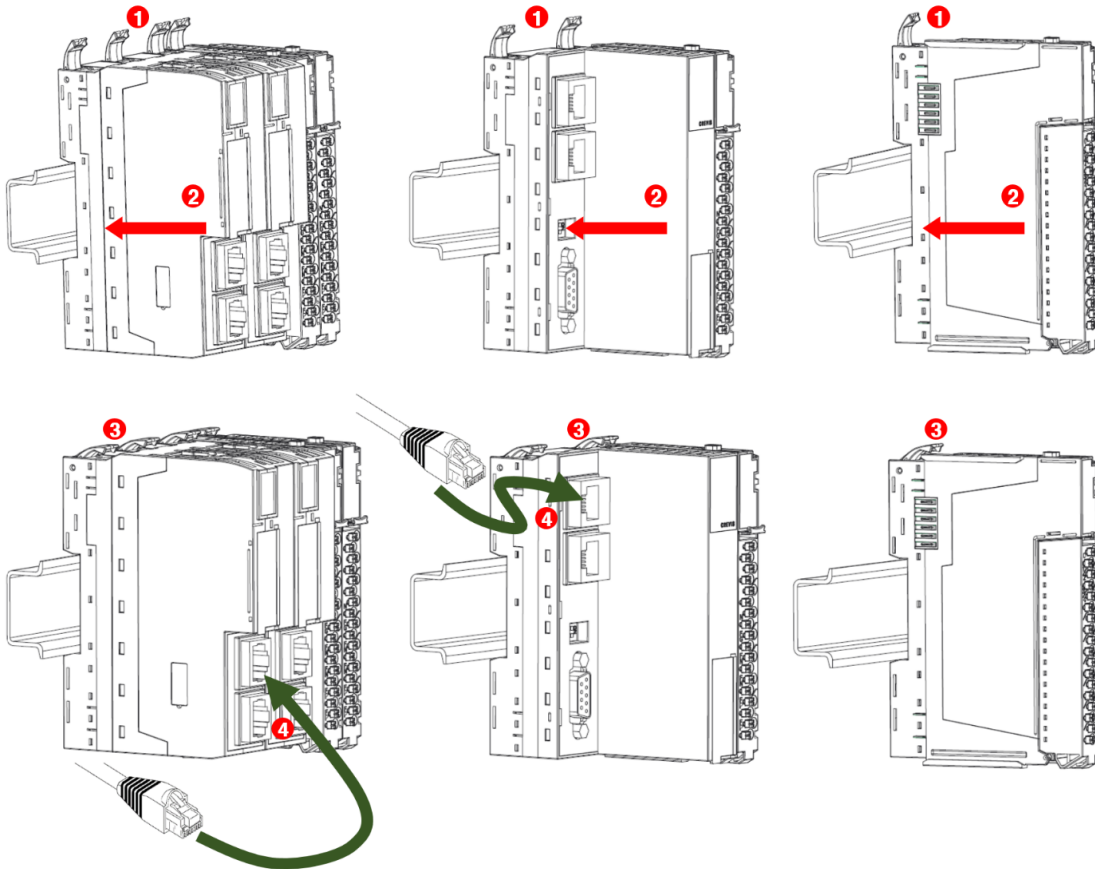

1. Unlock the DIN rail lock.
2. Push the module onto the DIN rail.
3. Lock the DIN rail lock to secure the module.
4. Connect the communication cable

Unmounting steps

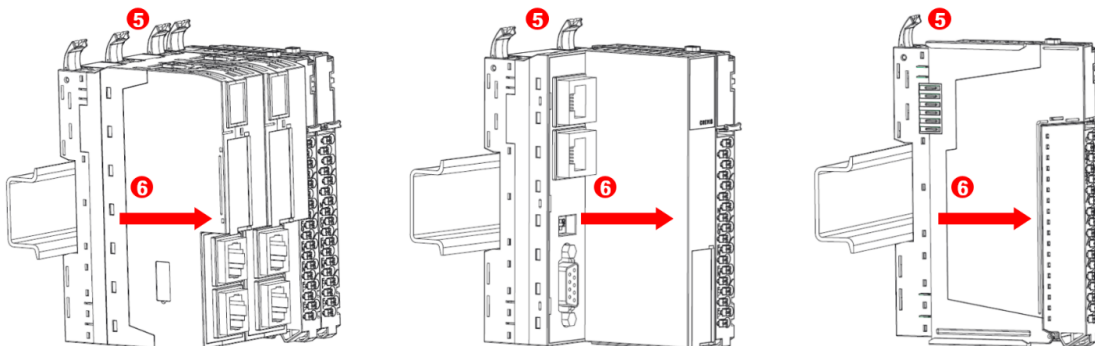

1. Unlock the DIN rail lock.
2. Pull the module away from the DIN rail.

12.3. Power Wiring

Each network adapter requires **both system power and field power**.

- **System power** supplies the system and Modbus TCP connection.
- **Field power** supplies the I/O connection.

For detailed power wiring instructions, refer to the [power module user manual](#).

12.3.1. Power Wiring Safety Information



WARNING

Only a qualified electrical engineer may perform power wiring.



CAUTION

- Always use standard cables.
- Insulate all unshielded wires with tape to prevent short circuits.
- Always keep system power and field power separate.
- When installing M-series modules in **marine environments**, connect a separate noise filter to the power supply. For more information, see the [M7151 Noise Filter Module](#) user manual.
- When using multiple power modules, short the **Primary Power Setting** to define one power module as the primary power module.

12.3.2. Power Wiring Setup Examples

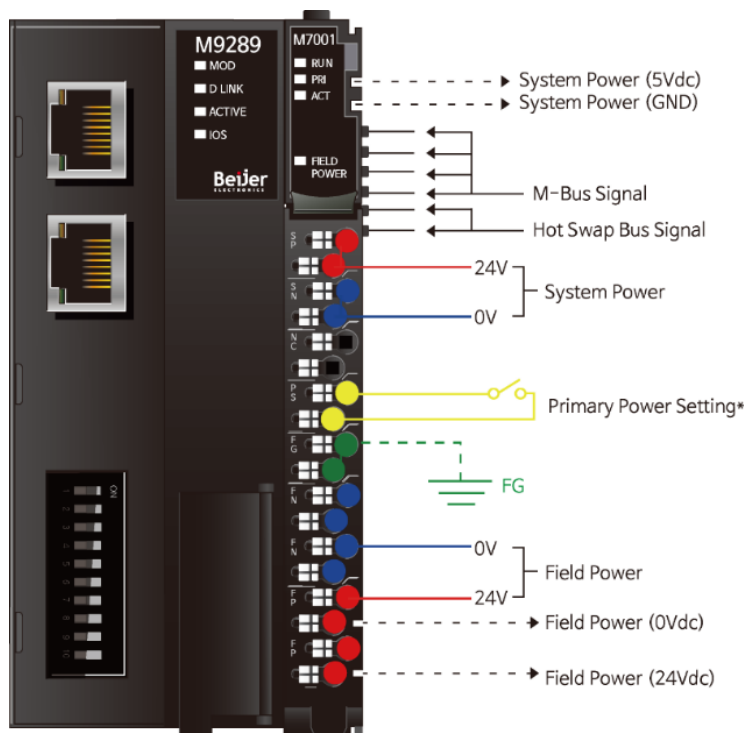

Single network adapter with one power module

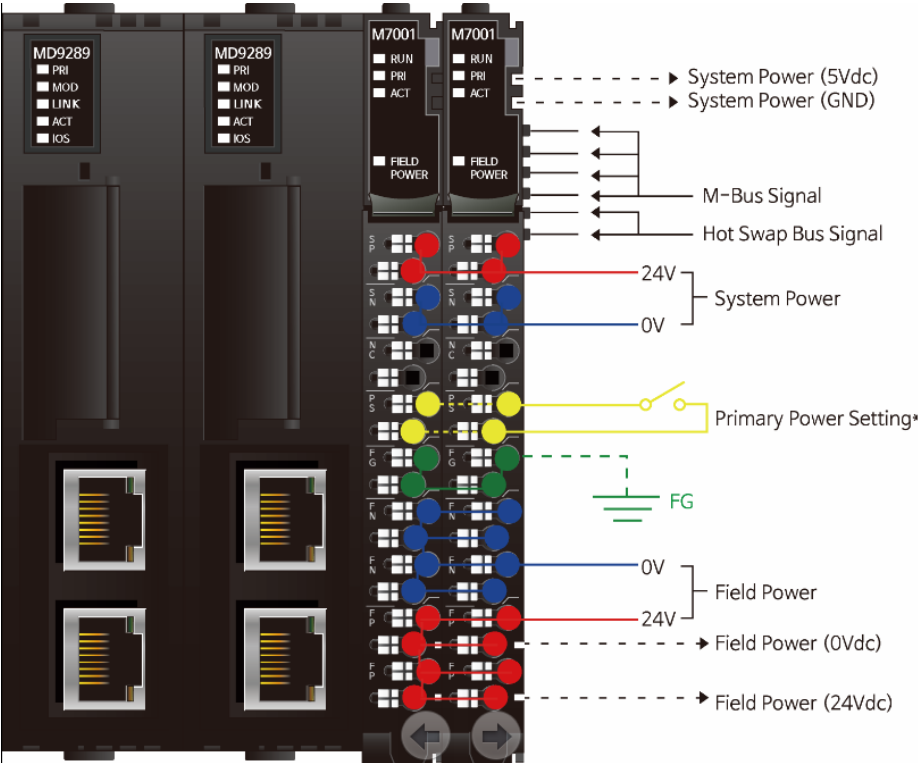

Dual network adapter with two power modules

13. Hot Swap (Module Replacement During Operation)

The M-series supports **hot swap**, allowing you to replace a module's **main block** without shutting down the system.

- If one **input or output module** fails, the other modules continue communication. When the faulty module is restored or replaced, full communication resumes.
- If one **power module** fails, the remaining power modules (if available) continue normal operation.
- In a **dual network adapter (MD9XXX)**, if one network adapter fails, the other continues to operate and protects the system.



NOTE

Hot swap is **not supported** for single network adapters (M9XXX) or programmable IO modules (M9XXX).

13.1. Hot Swap Safety Information



WARNING

- Always read the **General Safety Requirements** before performing hot swap.
- Removing the main block may generate sparks. **Do not** perform hot swaps in potentially explosive environments.
- Dangerous contact voltage may exist on connected I/O wiring. Before performing a hot swap, make sure **no external voltage** is present on the module's terminal connections. **Do not** touch live terminals during replacement.
- If a hot swap can cause a dangerous machine state, **disconnect the machine from power** before replacement.



IMPORTANT

- Removing or inserting a main block **may** place other modules in an **undefined state**.
- Replace main blocks **one at a time**. If more than one main block is removed, reinsert them one by one, starting with the lowest slot number.

13.2. Hot Swap Instructions

The hot swap procedure **varies depending on the module type**.

See the chapters below for instructions.

13.2.1. Hot Swap (I/O, Special, or Power Modules)

This chapter describes how to **hot swap** the main block on the following module types:

- Digital input modules (M1XXX)
- Digital output modules (M2XXX)

- Analog input modules (M3XXX)
- Analog output modules (M4XXX)
- Special modules (M5XXX)
- Power modules (M7XXX)

Replacement procedure

1. Unlock the removable terminal block (RTB).



2. Open the RTB to at least 90°.



3. Press the button on the top of the module frame.



4. Pull the main block straight out of the frame.

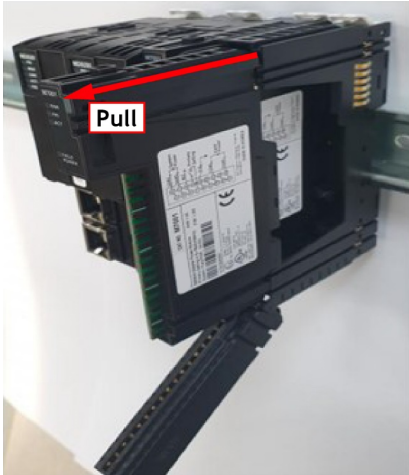

5. Hold the new main block by the head and carefully slide it into the backplane.
6. Reconnect the RTB.

13.2.2. Hot Swap (Dual Network Adapters)

This chapter describes how to **hot swap** the main block on the following module types:

- Dual network adapters (MD9XXX)

Replacement procedure

1. Press on top and bottom of the dual network adapter module frame.

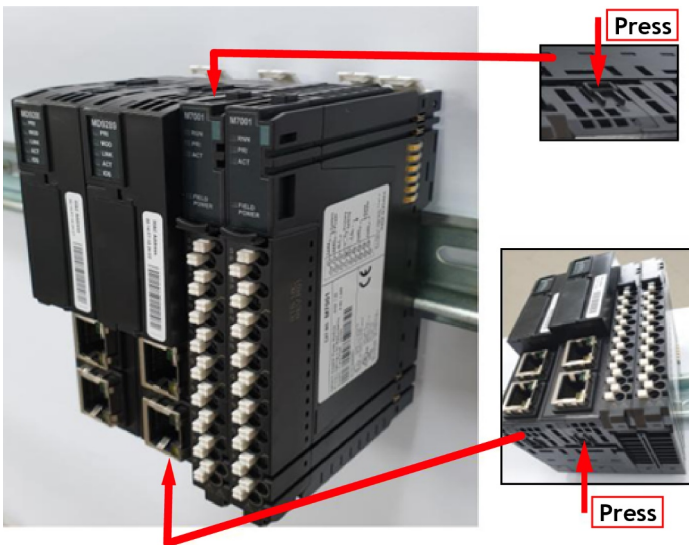

2. Pull the main block straight out of the frame.

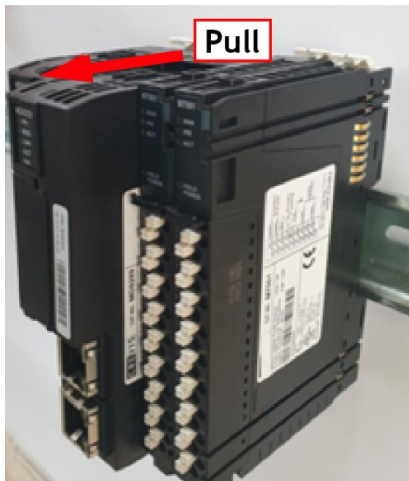

3. To insert, hold the new main block by the top and bottom, and carefully slide it into the backplane.