

User Manual

GT-3708 Analog Input Module

8 ch RTD input, PT100/PT1000/Ni1000LG etc., 12 bit resolution, 20 pt connector

Doc ID: 133799
2025-08-27

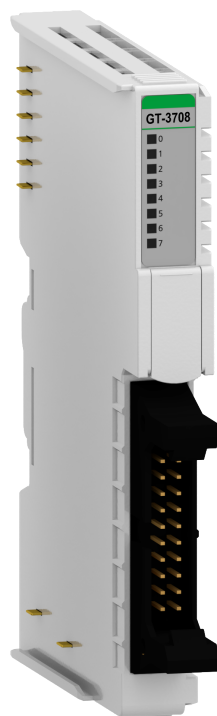

The information in this document is subject to change without notice and is provided as available at the time of printing. Beijer Electronics AB reserves the right to change any information without updating this publication. Beijer Electronics AB assumes no responsibility for any errors that may appear in this document. All examples in this document are only intended to improve understanding of the functionality and handling of the equipment. Beijer Electronics AB cannot assume any liability if these examples are used in real applications. In view of the wide range of applications for this software, users must acquire sufficient knowledge themselves in order to ensure that it is correctly used in their specific application. Persons responsible for the application and the equipment must themselves ensure that each application is in compliance with all relevant requirements, standards, and legislation in respect to configuration and safety. Beijer Electronics AB will accept no liability for any damage incurred during the installation or use of equipment mentioned in this document. Beijer Electronics AB prohibits all modification, changes, or conversion of the equipment.

Head Office

Beijer Electronics AB

Box 426

201 24 Malmö, Sweden

www.beijerelectronics.com / +46 40 358600

Table of Contents

1. About This Manual	5
1.1. Symbols Used in This Manual	5
2. Safety	6
2.1. Product Certifications	6
2.2. General Safety Requirements	6
3. About the G-series System	7
3.1. IO Process Data Mapping	8
4. Specifications	9
4.1. Environmental Specifications	9
4.2. General Specification	10
4.3. Input Specifications	10
5. Wiring Diagram	12
6. LED Indicator	13
6.1. LED Channel Status	13
7. Mapping Data Into the Image Table	14
8. Configuration Parameter - 18 byte	15
9. Data Value	17
10. Hardware Setup	18
10.1. Space Requirements	18
10.2. Mount Module to DIN Rail	19

1. About This Manual

This manual contains information on the software and hardware features of the Beijer Electronics GT-3708 Analog Input Module. It provides in-depth specifications, guidance on installation, setup, and usage of the product.

1.1. Symbols Used in This Manual

This publication includes Warning, Caution, Note and Important icons where appropriate, to point out safety-related, or other important information. The corresponding symbols should be interpreted as follows:



WARNING

The Warning icon indicates a potentially hazardous situation which, if not avoided, could result in death or serious injury, and major damage to the product.



CAUTION

The Caution icon indicates a potentially hazardous situation which, if not avoided, could result in minor or moderate injury, and moderate damage to the product.



NOTE

The Note icon alerts the reader to relevant facts and conditions.



IMPORTANT

The Important icon highlights important information.

2. Safety

Before using this product, please read this manual and other relevant manuals carefully. Pay full attention to safety instructions!

In no event will Beijer Electronics be responsible or liable for damages resulting from the use of this product.

The images, examples and diagrams in this manual are included for illustrative purposes. Because of the many variables and requirements associated with any particular installation, Beijer Electronics cannot take responsibility or liability for actual use based on the examples and diagrams.

2.1. Product Certifications

The product has the following product certifications.



2.2. General Safety Requirements



WARNING

- Do not assemble the products and wires with power connected to the system. Doing so cause an "arc flash", which can result in unexpected dangerous events (burns, fire, flying objects, blast pressure, sound blast, heat).
- Do not touch terminal blocks or IO modules when the system is running. Doing so may cause electric shock, short circuit or malfunction of the device.
- Never let external metallic objects touch the product when the system is running. Doing so may cause electric shock, short circuit or malfunction of the device.
- Do not place the product near inflammable material. Doing so may cause a fire.
- All wiring work should be performed by an electrical engineer.
- When handling the modules, ensure that all persons, the workplace and the packing are well grounded. Avoid touching conductive components, the modules contain electronic components that may be destroyed by electrostatic discharge.



CAUTION

- Never use the product in environments with temperature over 60°C. Avoid placing the product in direct sunlight.
- Never use the product in environments with over 90% humidity.
- Always use the product in environments with pollution degree 1 or 2.
- Use standard cables for wiring.

3. About the G-series System

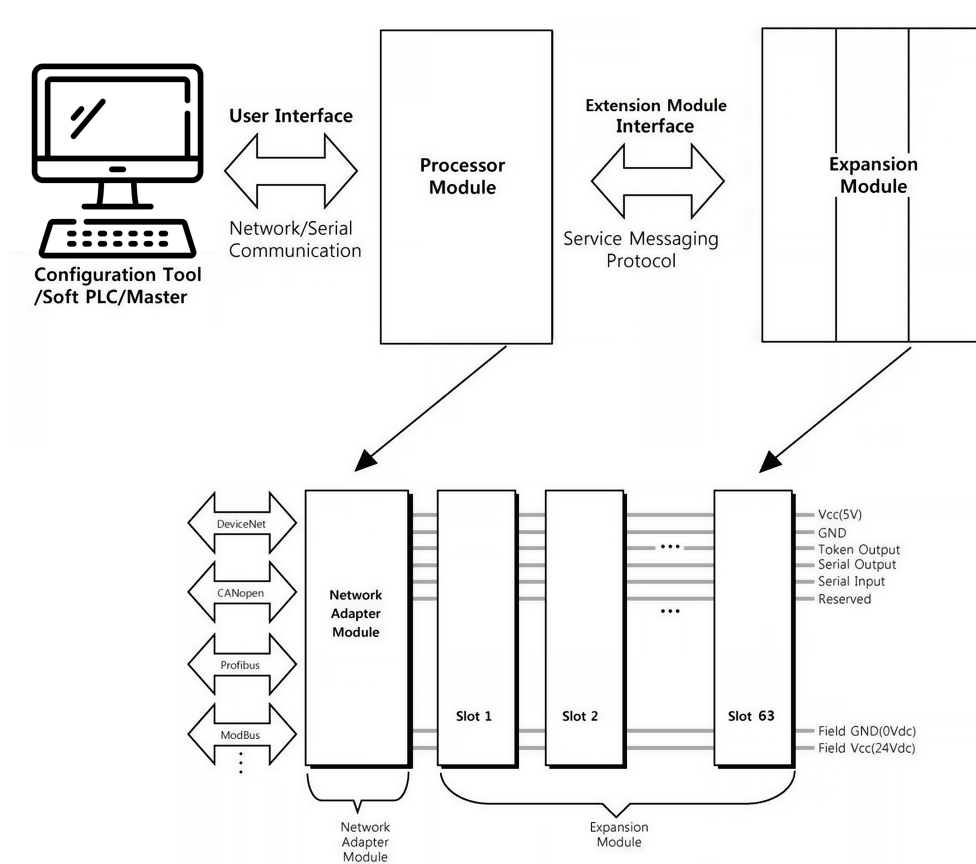

System overview

- **Network Adapter Module** - The network adapter module forms the link between the field bus and the field devices with the expansion modules. The connection to different field bus systems can be established by each of the corresponding network adapter module, e.g., for MODBUS TCP, Ethernet IP, EtherCAT, PROFINET, CC-Link IE Field, PROFIBUS, CANopen, DeviceNet, CC-Link, MODBUS/Serial etc.
- **Expansion Module** - Expansion module types: Digital IO, Analog IO, and Special modules.
- **Messaging** - The system uses two types of messaging: Service messaging and IO messaging.

3.1. IO Process Data Mapping

An expansion module has three types of data: IO data, configuration parameter, and memory register. The data exchange between the network adapter and the expansion modules is made via IO process image data by internal protocol.

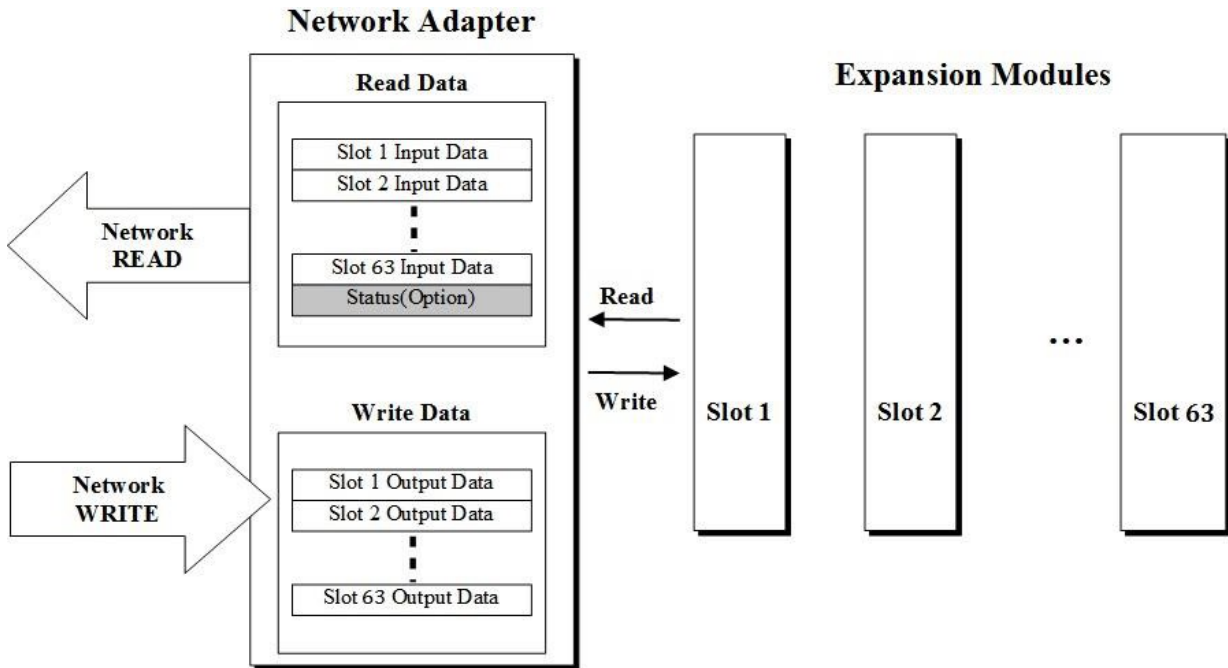

Data flow between network adapter (63 slots) and expansion modules

The input and output image data depend on the slot position and the data type of the expansion slot. The ordering of input and output process image data is based on the expansion slot position. Calculations for this arrangement are included in the manuals for network adapter and programmable IO modules.

Valid parameter data depends on the modules in use. For example, analog modules have settings of either 0-20 mA or 4-20 mA, and temperature modules have settings such as PT100, PT200, and PT500. The documentation for each module provides a description of the parameter data.

4. Specifications

4.1. Environmental Specifications

Operating temperature	-20°C - 60°C
UL temperature	-20°C - 60°C
Storage temperature	-40°C - 85°C
Relative humidity	5% - 90% non-condensing
Mounting	DIN rail
Shock operating	IEC 60068-2-27 (15G)
Vibration resistance	IEC 60068-2-6 (4 g)
Industrial emissions	EN 61000-6-4: 2019
Industrial immunity	EN 61000-6-2: 2019
Installation position	Vertical and horizontal
Product certifications	CE, FCC, UL, cUL

4.2. General Specification

Power dissipation	Max. 135 mA @ 5 VDC
Isolation	I/O to logic: Isolation Field power: Not connected
UL Field Power	Supply voltage: 24 VDC nominal, Class 2
Field power	Not used, field power bypass to the next expansion module
Wiring	Connector type, up to AWG22 Module connector: HIF3BA-20D-2.54DSA
Weight	60 g
Module size	12 mm x 99 mm x 70 mm

4.2.1. Dimensions

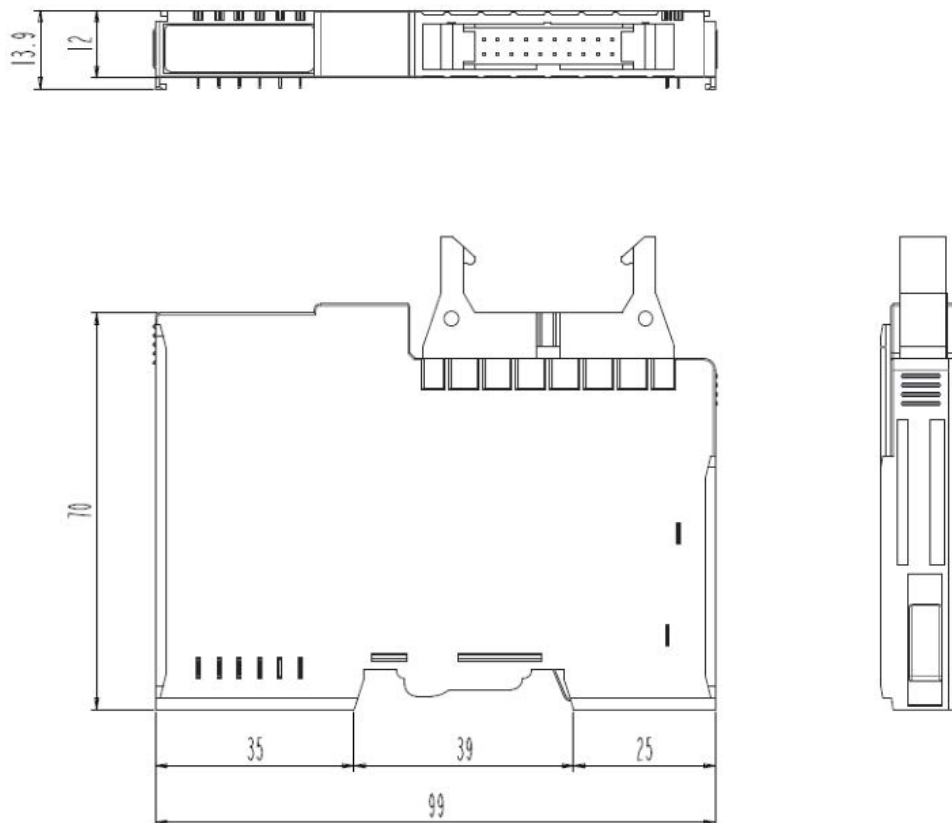

Module dimensions (mm)

4.3. Input Specifications

Inputs per module	8 channels
Indicators (logic side)	8 green input status

Inputs per module	8 channels																										
Sensor types	<p>RTD input range</p> <table border="1"> <thead> <tr> <th>RTD input</th> <th>Input range</th> </tr> </thead> <tbody> <tr> <td>PT50, PT100, PT200, PT500, PT1000</td> <td>-200 - 850 °C</td> </tr> <tr> <td>JPT50, JPT100, JPT200, JPT500, JPT1000</td> <td>-200 - 640 °C</td> </tr> <tr> <td>NI100, NI200, NI500, NI1000</td> <td>-60 - 250 °C</td> </tr> <tr> <td>NI120</td> <td>-80 - 260 °C</td> </tr> <tr> <td>Cu10, Cu100</td> <td>-100 - 260 °C</td> </tr> <tr> <td>NI1000LG</td> <td>-50 - 120 °C</td> </tr> </tbody> </table> <table border="1"> <thead> <tr> <th>Resistance input</th> <th>Input range</th> </tr> </thead> <tbody> <tr> <td>1 Ω/bit</td> <td>0 - 4000 Ω</td> </tr> <tr> <td>100 mΩ/bit</td> <td>0 - 2000 Ω</td> </tr> <tr> <td>10 mΩ/bit</td> <td>0 - 327 Ω</td> </tr> <tr> <td>20 mΩ/bit</td> <td>0 - 620 Ω</td> </tr> <tr> <td>50 mΩ/bit</td> <td>0 - 1200 Ω</td> </tr> </tbody> </table>	RTD input	Input range	PT50, PT100, PT200, PT500, PT1000	-200 - 850 °C	JPT50, JPT100, JPT200, JPT500, JPT1000	-200 - 640 °C	NI100, NI200, NI500, NI1000	-60 - 250 °C	NI120	-80 - 260 °C	Cu10, Cu100	-100 - 260 °C	NI1000LG	-50 - 120 °C	Resistance input	Input range	1 Ω/bit	0 - 4000 Ω	100 mΩ/bit	0 - 2000 Ω	10 mΩ/bit	0 - 327 Ω	20 mΩ/bit	0 - 620 Ω	50 mΩ/bit	0 - 1200 Ω
RTD input	Input range																										
PT50, PT100, PT200, PT500, PT1000	-200 - 850 °C																										
JPT50, JPT100, JPT200, JPT500, JPT1000	-200 - 640 °C																										
NI100, NI200, NI500, NI1000	-60 - 250 °C																										
NI120	-80 - 260 °C																										
Cu10, Cu100	-100 - 260 °C																										
NI1000LG	-50 - 120 °C																										
Resistance input	Input range																										
1 Ω/bit	0 - 4000 Ω																										
100 mΩ/bit	0 - 2000 Ω																										
10 mΩ/bit	0 - 327 Ω																										
20 mΩ/bit	0 - 620 Ω																										
50 mΩ/bit	0 - 1200 Ω																										
Excitation current	About 0.5 mA																										
Connection method	3-wire																										
Conversion time	55 ms / all channels																										
Data format	16 bits signed integer (2' complement)																										
Module accuracy	<p>PT1000: ±0.3 °C at 50 - 150 °C @ 25 °C ambient PT1000: ±0.5 °C at 50 - 150 °C @ -40, 70 °C ambient PT1000: ±0.5 °C at -200 - 250 °C @ 25 °C ambient PT1000: ±1 °C at 250 - 850 °C @ 25 °C ambient Cu10: ±2 % full scale @ 25 °C ambient Cu10: ±4 % full scale @ -40, 70 °C ambient Cu100: ±0.3 % full scale @ 25 °C ambient Cu100: ±0.5 % full scale @ -40, 70 °C ambient</p> <p>All type input range:</p> <ul style="list-style-type: none"> • ±0.1 % full scale @ 25 °C ambient • ±0.3 % full scale @ -40 - 70 °C 																										
Resolution of data	RTD Type : ±0.1 °C / F , Resistance type: 1 Ω, 100 mΩ, 10 mΩ, 20 mΩ, 50 mΩ																										
Calibration	Not required																										
Diagnostic	Sensor open or range over, then conversion data = 0x8000(-32768)																										

5. Wiring Diagram

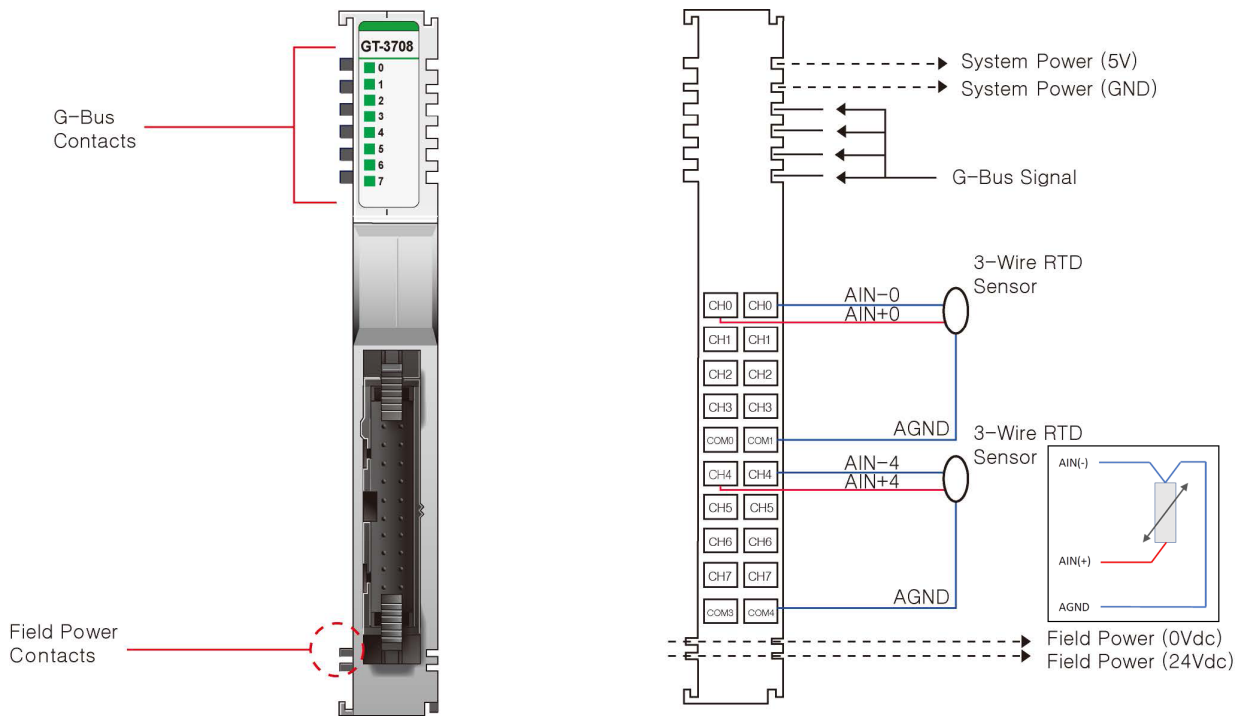

Pin no.	Signal description
0	RTD channel 0+
1	RTD channel 0-
2	RTD channel 1+
3	RTD channel 1-
4	RTD channel 2+
5	RTD channel 2-
6	RTD channel 3+
7	RTD channel 3-
8	AGND
9	AGND
10	RTD channel 4+
11	RTD channel 4-
12	RTD channel 5+
13	RTD channel 5-
14	RTD channel 6+
15	RTD channel 6-
16	RTD channel 7+
17	RTD channel 7-
18	AGND
19	AGND

6. LED Indicator

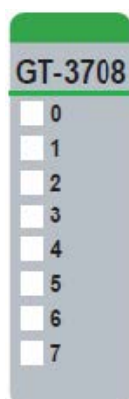

LED no.	LED function / description	LED color
0	INPUT channel 0	Green
1	INPUT channel 1	Green
2	INPUT channel 2	Green
3	INPUT channel 3	Green
4	INPUT channel 4	Green
5	INPUT channel 5	Green
6	INPUT channel 6	Green
7	INPUT channel 7	Green

6.1. LED Channel Status

Status	LED	Indication
No signal Normal operation	OFF	Input sensor open or input range over Normal operation
On signal Normal operation	Green	Sensor connected and input range valid Normal operation

7. Mapping Data Into the Image Table

Input module data

Analog input Ch 0
Analog input Ch 1
Analog input Ch 2
Analog input Ch 3
Analog input Ch 4
Analog input Ch 5
Analog input Ch 6
Analog input Ch 7



Input image value

Bit no.	Bit 7	Bit 6	Bit 5	Bit 4	Bit 3	Bit 2	Bit 1	Bit 0
Byte 0	Analog input Ch 0 low byte							
Byte 1	Analog input Ch 0 high byte							
Byte 2	Analog input Ch 1 low byte							
Byte 3	Analog input Ch 1 high byte							
Byte 4	Analog input Ch 2 low byte							
Byte 5	Analog input Ch 2 high byte							
Byte 6	Analog input Ch 3 low byte							
Byte 7	Analog input Ch 3 high byte							
Byte 8	Analog input Ch 4 low byte							
Byte 9	Analog input Ch 4 high byte							
Byte 10	Analog input Ch 5 low byte							
Byte 11	Analog input Ch 5 high byte							
Byte 12	Analog input Ch 6 low byte							
Byte 13	Analog input Ch 6 high byte							
Byte 14	Analog input Ch 7 low byte							
Byte 15	Analog input Ch 7 high byte							



NOTE

If the input of the channel is open or over-ranged, its conversion data will be 0x8000(-32678).

8. Configuration Parameter - 18 byte

Byte	Decimal bit	Description	Default value
0	00-07	<p>The selection sensor type</p> <p>=00h:PT100, 0.00385, -200 - 850 °C, 0.1 °C /count</p> <p>=01h:PT200, 0.00385, -200 - 850 °C, 0.1 °C/count</p> <p>=02h:PT500, 0.00385, -200 - 850 °C, 0.1 °C/count</p> <p>=03h:PT1000, 0.00385, -200 - 850 °C, 0.1 °C/count</p> <p>=04h:PT50, 0.00385, -200 - 850 °C, 0.1 °C/count</p> <p>=10h:JPT100, 0.003916, -200 - 640 °C, 0.1 °C/count</p> <p>=11h:JPT200, 0.003916, -200 - 640 °C, 0.1 °C/count</p> <p>=12h:JPT500, 0.003916, -200 - 640 °C, 0.1 °C/count</p> <p>=13h:JPT1000, 0.003916, -200 - 640 °C, 0.1 °C/count</p> <p>=14h:JPT50, 0.003916, -200 - 640 °C, 0.1 °C/count</p> <p>=20h:NI100, 0.00618, -60 - 250 °C, 0.1 °C/count</p> <p>=21h:NI200, 0.00618, -60 - 250 °C, 0.1 °C/count</p> <p>=22h:NI500, 0.00618, -60 - 250 °C, 0.1 °C/count</p> <p>=23h:NI1000, 0.00618, -60 - 250 °C, 0.1 °C/count</p> <p>=30h:NI120, 0.00672, -80 - 260 °C, 0.1 °C/count</p> <p>=40h:Cu10, 0.00427, -100 - 260 °C, 0.1 °C/count</p> <p>=41h:Cu100, 0.00427, -100 - 260 °C, 0.1 °C/count</p> <p>=53h:NI1000LG, 0.00500, -50 - 120 °C, 0.1 °C/count</p> <p>=80h:Resistance Input, 1 - 2000 Ω, 100 mΩ /1count</p> <p>=81h:Resistance Input, 1 - 327 Ω, 10 mΩ /1count</p> <p>=82h:Resistance Input, 1 - 620 Ω, 20 mΩ /1count</p> <p>=83h: Resistance Input, 1 - 1200 Ω, 50 mΩ/1count</p> <p>=84h: Resistance Input, 1 - 4000 Ω, 1 Ω/1count</p>	0: PT100
1	00	<p>Temperature type:</p> <p>0: Celsius (°C)</p> <p>1: Fahrenheit (°F)</p>	00: Celsius (°C)
	01	Reserved	0
	02 - 03	<p>Data resolution:</p> <p>00: 0.1 °C, °F/bit</p> <p>01: 1 °C, °F/bit</p> <p>10: 0.01 °C, °F/bit *</p> <p>11: Reserved</p>	0

Byte	Decimal bit	Description	Default value
	04	Filter type: 0: Normal filter 1: Enhanced filter	0: Normal filter
	05-06	SW filter: 0: Normal filter (filter time = 20) 1: Fast filter (filter time = 3) ** 2: Enhanced filter (filter time = 40) 3: More enhanced filter (filter time = 80)	0
	07	Reserved	0
2-3		CH0 offset value	0
4-5		CH1 offset value	0
6-7		CH2 offset value	0
8-9		CH3 offset value	0
10-11		CH4 offset value	0
12-13		CH5 offset value	0
14-15		CH6 offset value	0
16-17		CH7 offset value	0

* Data exceeding 32767 cannot be displayed.

** If fast filter is set, the specification accuracy may not be met.

9. Data Value

Resistance temperature detector input range

Type	Input range
PT100	-200 - 850 °C
PT200	-200 - 850 °C
PT500	-200 - 850 °C
PT1000	-200 - 850 °C
PT50	-200 - 850 °C
JPT100	-200 - 640 °C
JPT200	-200 - 640 °C
JPT500	-200 - 640 °C
JPT1000	-200 - 640 °C
JPT50	-200 - 640 °C
NI100	-60 - 250 °C
NI200	-60 - 250 °C
NI500	-60 - 250 °C
NI1000	-60 - 250 °C
NI120	-80 - 260 °C
Cu10	-100 - 260 °C
Cu100	-100 - 260 °C
NI1000LG	-50 - 120 °C

Resistance input range

Type	Input range
1 Ω/bit	0 - 4000 Ω
100 mΩ/bit	0 - 2000 Ω
10 mΩ/bit	0 - 327 Ω
20 mΩ/bit	0 - 620 Ω
50 mΩ/bit	0 - 1200 Ω

10. Hardware Setup



CAUTION

- Always read this chapter before installing the module!
- Hot surface! The surface of the housing can become hot during operation. If the device is used in high ambient temperatures, always let the device cool down before touching it.
- Working on energized devices can damage the equipment! Always turn off the power supply before working on the device.

10.1. Space Requirements

The following drawings show the space requirements when installing the G-series modules. The spacing creates space for ventilation, and prevents conducted electromagnetic interference from influencing the operation. Installation position is valid vertical and horizontal. The drawings are illustrative and may be out of proportion.



CAUTION

Not following the space requirements may result in damaging the product.

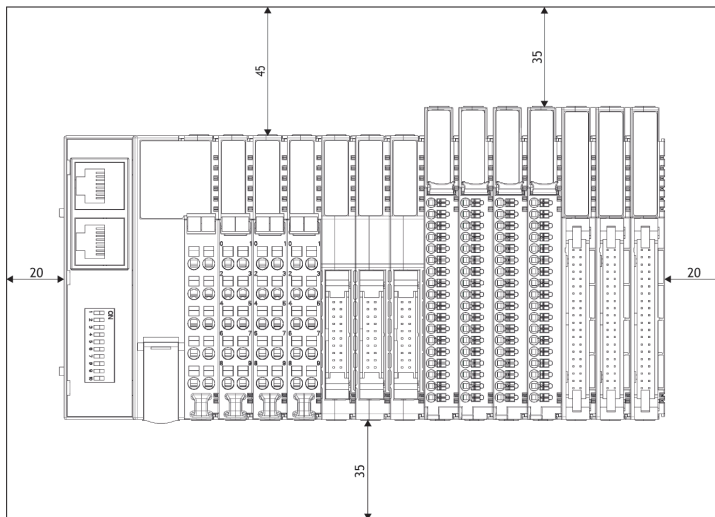

Vertical and horizontal space requirements

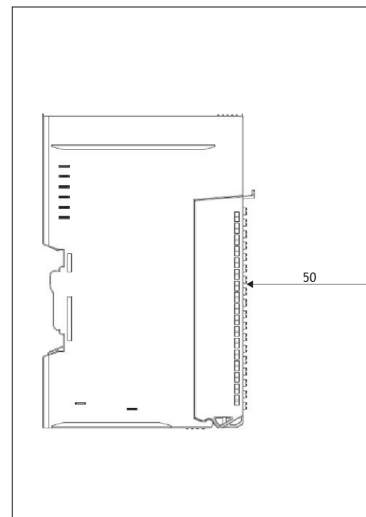

Required distance to door

10.2. Mount Module to DIN Rail

The following chapters describe how to mount the module to the DIN rail.



CAUTION

The module must be fixed to the DIN rail with the locking levers.

10.2.1. Mount GL-9XXX or GT-XXXX Module

The following instructions apply to these module types:

- GL-9XXX
- GT-1XXX
- GT-2XXX
- GT-3XXX
- GT-4XXX
- GT-5XXX
- GT-7XXX

GN-9XXX modules have three locking levers, one at the bottom and two on the side. For mounting instructions, refer to [Mount GN-9XXX Module](#).



Mount to DIN rail

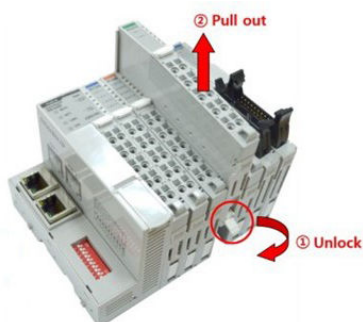

Dismount from DIN rail

10.2.2. Mount GN-9XXX Module

To mount or dismount a network adapter or programmable IO module with the product name GN-9XXX, for example GN-9251 or GN-9371, see the following instructions:

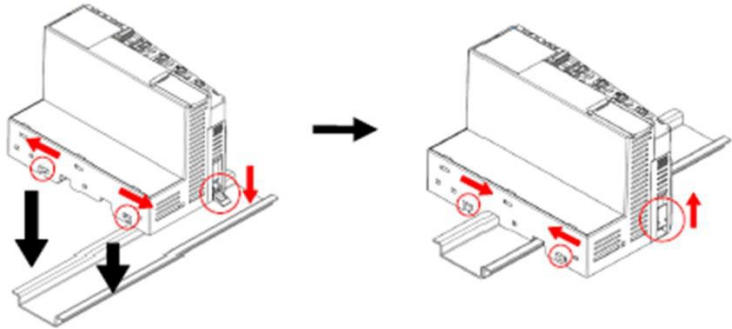

Mount to DIN rail

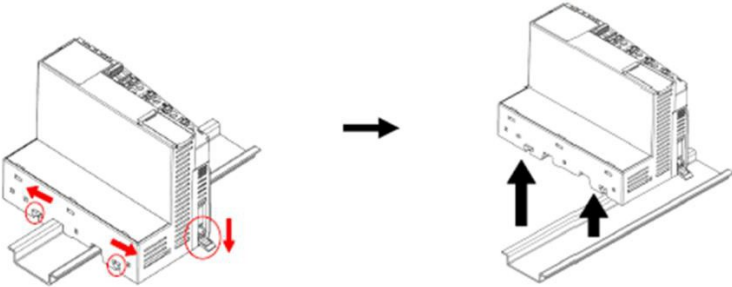

Dismount from DIN rail